

# 5002X DIE GRINDER

## EXPLODED VIEW

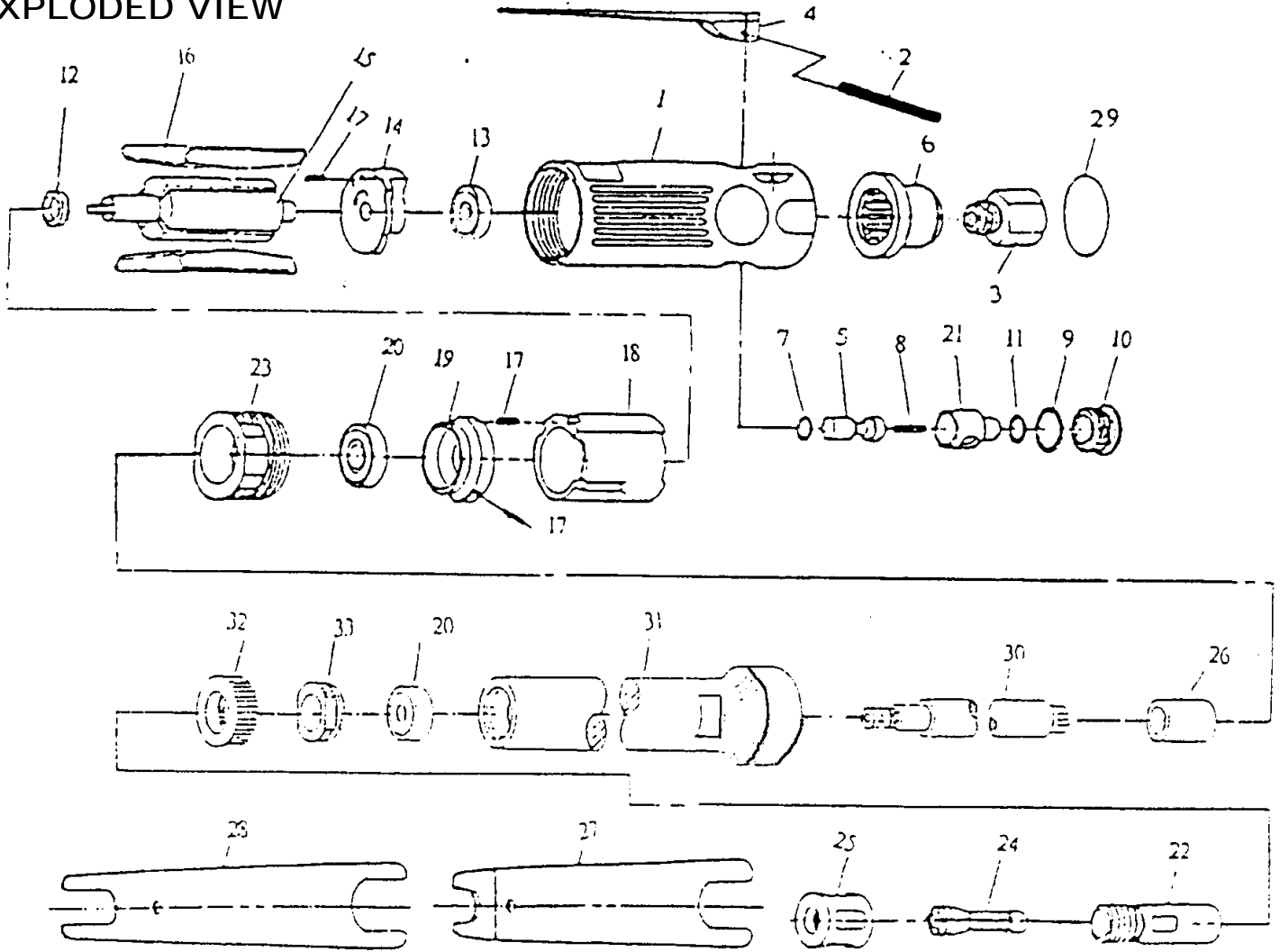

## PARTS LIST – FOR REFERENCE ONLY

Index Number	Part Number	Description	Qty.	Index Number	Part Number	Description	Qty.	Index Number	Part Number	Description	Qty.
1	YS-1201E	Motor Housing	1	12	YS-1212E	Rotor Bush	1	23	YS-1223E	Retainer	1
2	YS-1202E	Lever Pin	1	13	YS-1213E	Ball Bearing	1	24	YS-1224E	Collet	1
3	YS-1203E	Air Inlet	1	14	YS-1214E	Rear End Plate	1	25	YS-1225E	Collet Nut	1
4	YS-1204E	Throttle Lever	1	15	YS-1215E	Rotor	1	26	YS-1226E	Coupling	1
5	YS-1205E	Valve Stem	1	16	YS-1216E	Rotor Blades	4	27	YS-1227E	Angle Double Ended Spanner	1
6	YS-1206E	Exhaust Deflector	1	17	YS-1217E	Pin	3	28	YS-1228E	Double Ended Spanner	1
7	YS-1207E	O-Ring	1	18	YS-1218E	Cylinder	1	29	YS-1229E	Retainer Ring	1
8	YS-1208E	Valve Spring	1	19	YS-1219E	Front End Plate	1	30	YS-1230E	Extension Bar	1
9	YS-1209E	O-Ring	1	20	YS-1220E	Ball Bearing	2	31	YS-1231E	Extension Housing	1
10	YS-1210E	Throttle Valve Plug	1	21	YS-1221E	Air Regulator	1	32	YS-1232E	Cap	1
11	YS-1211E	O-Ring	1	22	YS-1222E	Spindle	1	33	YS-1233E	Retainer	1

### TECHNICAL DATA

	Max Air Pressure	Recommended Air Hose Size	RPM Free Speed	Max Air Flow CFM	Weight (lbs.)
5002X	90 psi	3/8"	22,000	10	1.4

### FOOTNOTES

When ordering spare parts, please specify tool type, part number and description

10000 SE PINE, PORTLAND, OR 97216  
503-254-1749 FAX 503-256-4026

REVISED 7/99

