

# 6016A

## 3/4" X 20 1/2" MINI-BELT SANDER

### EXPLODED VIEW

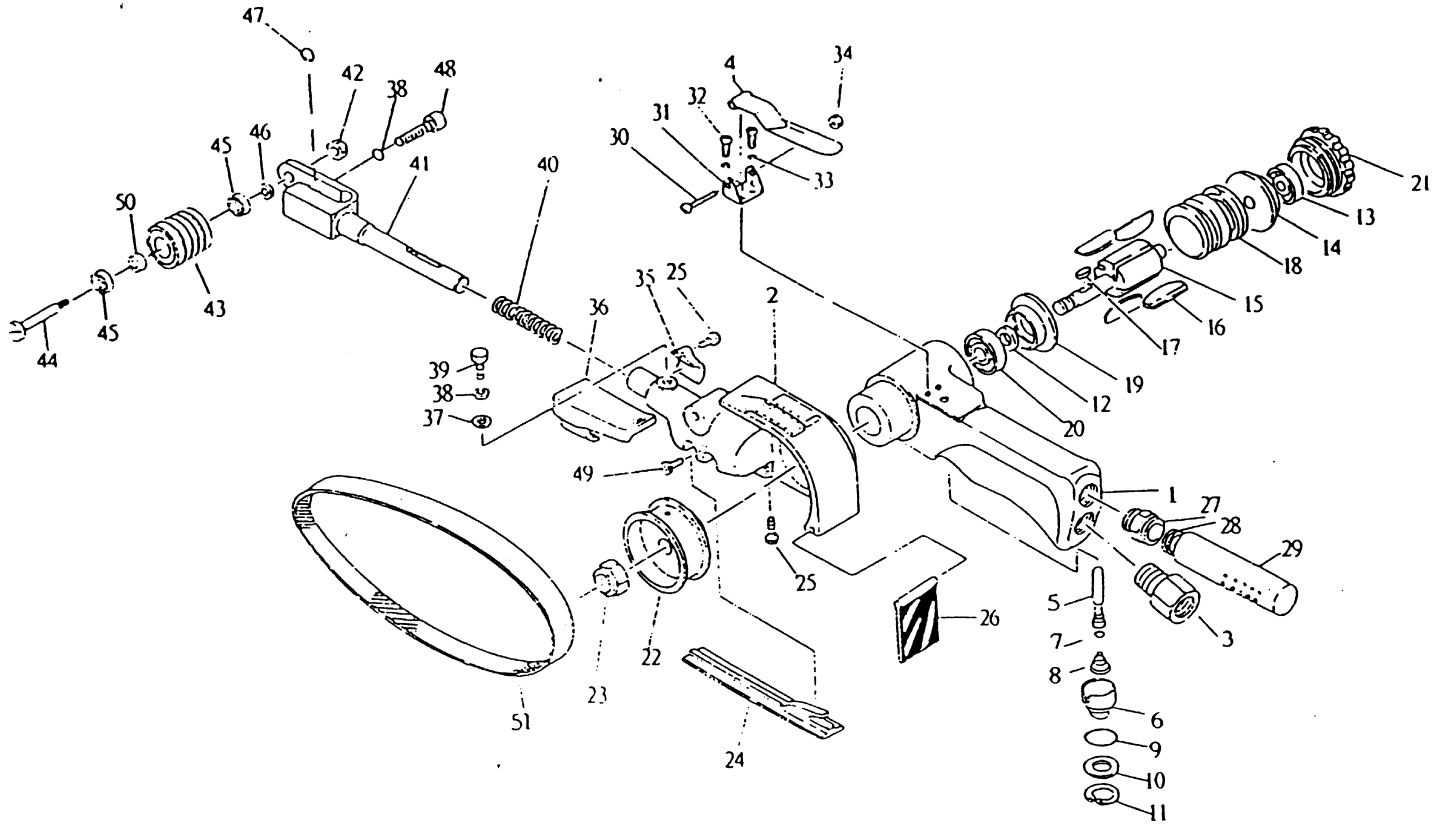

### PARTS LIST – FOR REFERENCE ONLY

Index Number	Part Number	Description	Qty.	Index Number	Part Number	Description	Qty.	Index Number	Part Number	Description	Qty.
1	62001	Housing	1	18	62018	Cylinder	1	35	62035	Bushing	1
2	62002	Guard Sub	1	19	62019	Front end Plate	1	36	62036	Finger Pad	1
3	62003	Air Inlet	1	20	62020	Ball Bearing	1	37	62037	Washer	1
4	62004	Lever	1	21	62021	Cap	1	38	65038	Spring Washer	2
5	62005	Valve Stem	1	22	62022	Drive Pulley	1	39	62039	Screw	1
6	62006	Adjust Valve	1	23	62023	Hexagon nut	1	40	62040	Spring	1
7	62007	O Ring	1*	24	62024	Flat Shoe	1	41	62041	Arm	1
8	62008	Spring	1	25	62025	Hexagon socket head bolt	1	42	62042	Nut	1**
9	62009	O Ring	1*	26	62026	Dust cover	1*	43	62043	Idle Pulley	1**
10	62010	Spacer	1	27	62027	Nipple	1	44	62044	Shaft	1**
11	62011	Retaining ring	1*	28	62028	Spring	1	45	62045	Ball Bearing	1**
12	62012	Distance Collar	1	29	62029	Silencer	1	46	62046	Spacer	1**
13	62013	Ball Bearing	1	30	62030	Pan Head Machine Scw.1	1	47	62047	Retaining Ring	1**
14	62014	Rear End Plate	1	31	62031	Lever Support	1	48	62048	Bolt	1
15	62015	Rotor	1	32	62032	Pan Head Machine Scw.1	3	49	62049	Bolt	1
16	62016	Blade	4*	33	62033	Spring Washer	2	50	62050	Spacer	1**
17	62017	Key	1	34	62034	Hexagon Nut	1	51	62051	Grinding Belt	1

#### TECHNICAL DATA

	Max Air Pressure	Recommended Air Hose Size	RPM Free Speed	Max Air Flow CFM	Weight (lbs.)
6016A	90 psi	3/8"	16,000	18.4	3.1

#### FOOTNOTES

- \* Parts Availabl in Repair Kit 6016A-RK\*
- \*\* Parts Availabl in Repair Kit 6016A-RBK\*



When ordering spare parts, please specify tool type, part number and description

10000 SE PINE, PORTLAND, OR 97216  
503-254-1749 FAX 503-256-4026

REVISED 7/99