

NOTES :

- 1 FREE SPEED - 1500 RPM
- 2 MAX TORQUE - 20 NM
- 3 WEIGHT - 2.5 LBS. / 1.1 KG.
- 4 OUTPUT - 3/8" SQ. DRIVE

REVISIONS

REV.	DESCRIPTION	ECN	DATE	BY	APPRVD
A	PRODUCTION RELEASE	---	5-23-01	JFB	PP

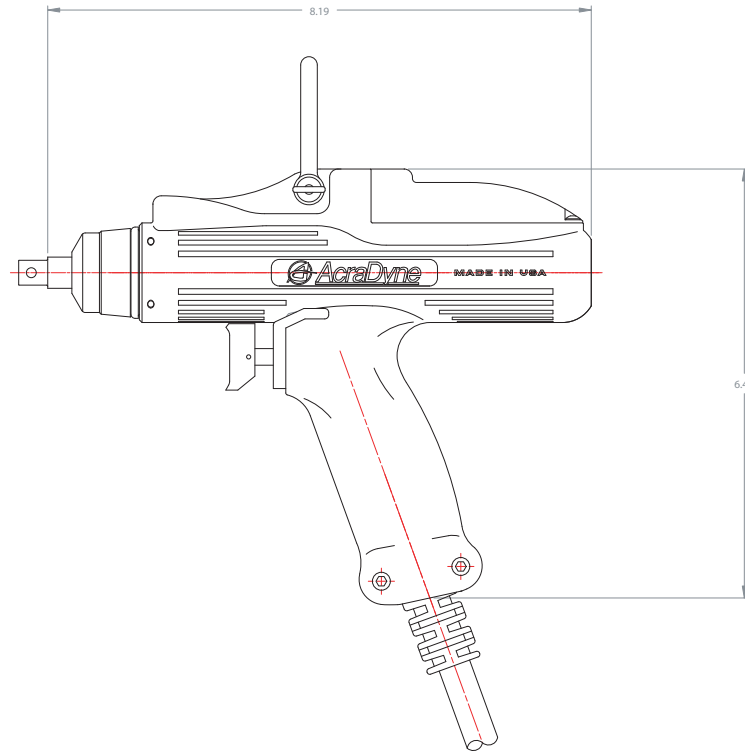
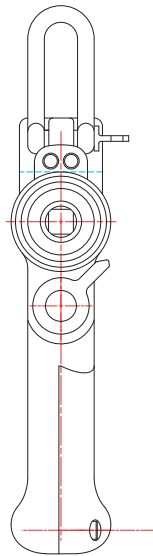
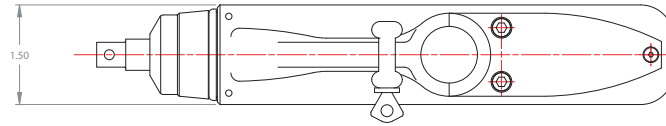

PRINTED COPIES OF THIS DOCUMENT ARE CONSIDERED TO BE UNCONTROLLED. HOLDERS ARE RESPONSIBLE FOR VERIFYING THE CURRENT REVISION LEVEL WITH PURCHASING OR THE DOCUMENT COORDINATOR PRIOR TO USE. THE CONTROLLED VERSION OF THIS DOCUMENT IS ELECTRONICALLY MAINTAINED.

THIS DRAWING EMBODIES CONFIDENTIAL INFORMATION OF ACRADYNE INCORPORATED. IN THE ABSENCE OF EXPRESSED WRITTEN PERMISSION, ACRADYNE HAS LOANED THIS COPY WITH THE UNDERSTANDING THAT: A) IT WOULD BE USED FOR ANY PURPOSE EXCEPT THAT FOR WHICH IT WAS LOANED; B) DATA CONTAINED THEREIN SHALL NOT BE DISCLOSED TO OTHERS; C) IT WILL NOT BE REPRODUCED; D) IT WILL BE RETURNED ON DEMAND TO ACRADYNE INC.

UNLESS OTHERWISE SPECIFIED DIMENSIONS ARE IN INCHES  
DIMENSIONS AND TOLERANCES PER ANSI Y14.36  
SURFACE ROUGHNESS PER ANSI Y14.36

TOLERANCES ON DECIMALS:  
X = ±.030      XXX = ±.005  
XX = ±.010     XXXX = ±.0005  
ANGLE = ±0° 30'

REMOVE BURRS AND SHARP EDGES .01 SR. MAX.  
MACHINE SURFACE FINISH: 125 RMS OR BETTER

DRAWN JFB 5-23-01  
CHECKED KJD  
APPROVED PP



ACRADYNE INC.  
1204 E. MAPLE  
TROY, MI. 48083 U.S.A.

**OUTLINE - AEP 2020**  
2000 SERIES 3/8" DR.

PROJECT NO. 2000

SIZE **D** PART NO. 21508

DRAWING NO. 21508

DO NOT SCALE DRAWING

SCALE 1:1 SHEET OF 1 1 REVISION A