

NOTES :

- 1 FREE SPEED - 400 RPM
- 2 MAX TORQUE - 68 NM
- 3 WEIGHT - 3.16 LBS. / 1.4 KG
- 4 OUTPUT - 3/8" SQ. DRIVE

REVISIONS

REV.	DESCRIPTION	ECN	DATE	BY	APPRVD
A	PRODUCTION RELEASE	---	5-23-01	JFB	PP

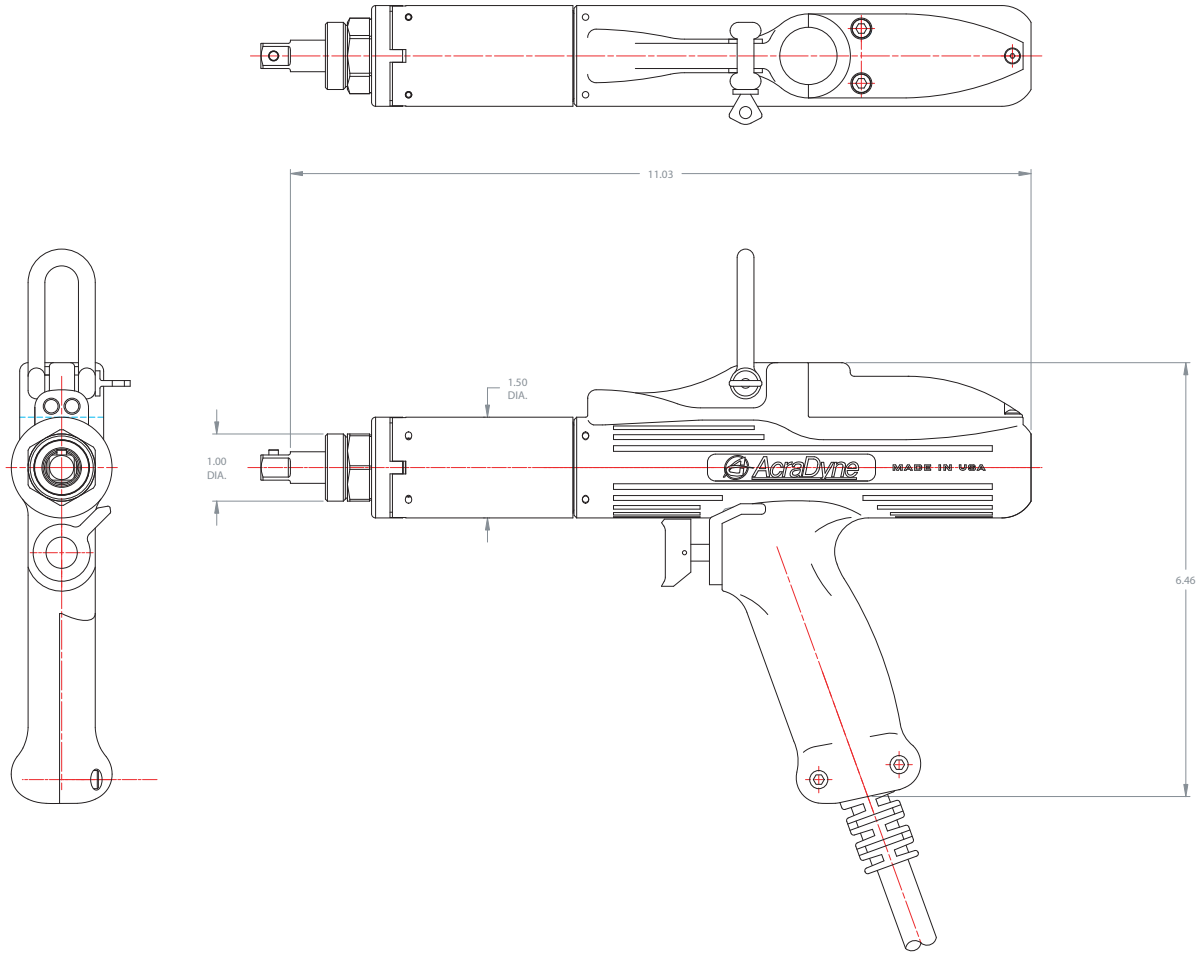

PRINTED COPIES OF THIS DOCUMENT ARE CONSIDERED TO BE UNCONTROLLED. HOLDERS ARE RESPONSIBLE FOR VERIFYING THE CURRENT REVISION LEVEL WITH PURCHASING OR THE DOCUMENT COORDINATOR PRIOR TO USE. THE CONTROLLED VERSION OF THIS DOCUMENT IS ELECTRONICALLY MAINTAINED.

THIS DRAWING COMBINES CONFIDENTIAL INFORMATION OF ACRADYNE INCORPORATED. IN THE ABSENCE OF EXPRESSED WRITTEN PERMISSION, ACRADYNE HAS LOANED THIS COPY WITH THE UNDERSTANDING THAT: AS IT WOULD BE USED FOR ANY PURPOSE EXCEPT THAT FOR WHICH IT WAS LOANED; BE DATA CONTAINED THEREIN SHALL NOT BE REPRODUCED TO OTHERS; CIT WILL NOT BE REPRODUCED; IF IT WILL BE RETURNED ON DEMAND TO ACRADYNE INC.

UNLESS OTHERWISE SPECIFIED DIMENSIONS ARE IN INCHES
DIMENSIONS AND TOLERANCES PER ANSI Y14.36
SURFACE ROUGHNESS PER ANSI Y14.36
TOLERANCES ON DECIMALS:
X = ±.005 XXX = ±.005
XX = ±.010 XXXX = ±.005
ANGLE = ±0° 30'

REMOVE BURRS AND SHARP EDGES 0.10R MAX.
MACHINE SURFACE FINISH: 125 RMS OR BETTER.

DRAWN	JFB 5-23-01	 <p>ACRADYNE INC. 1204 E. MAPLE TROY, MI, 48063 U.S.A.</p>					
CHECKED	KJD						
APPROVED	PP						
PROJECT NO.	2000	<p>OUTLINE - AEM 2068 2000 SERIES TRIPLE STEP 3/8" DR.</p>					
SIZE	D	PART NO.	21511	DRAWING NO.	21511		
DO NOT SCALE DRAWING		SCALE	1:1	SHEET OF 1	1	REVISION	A