

EXPLODED VIEW

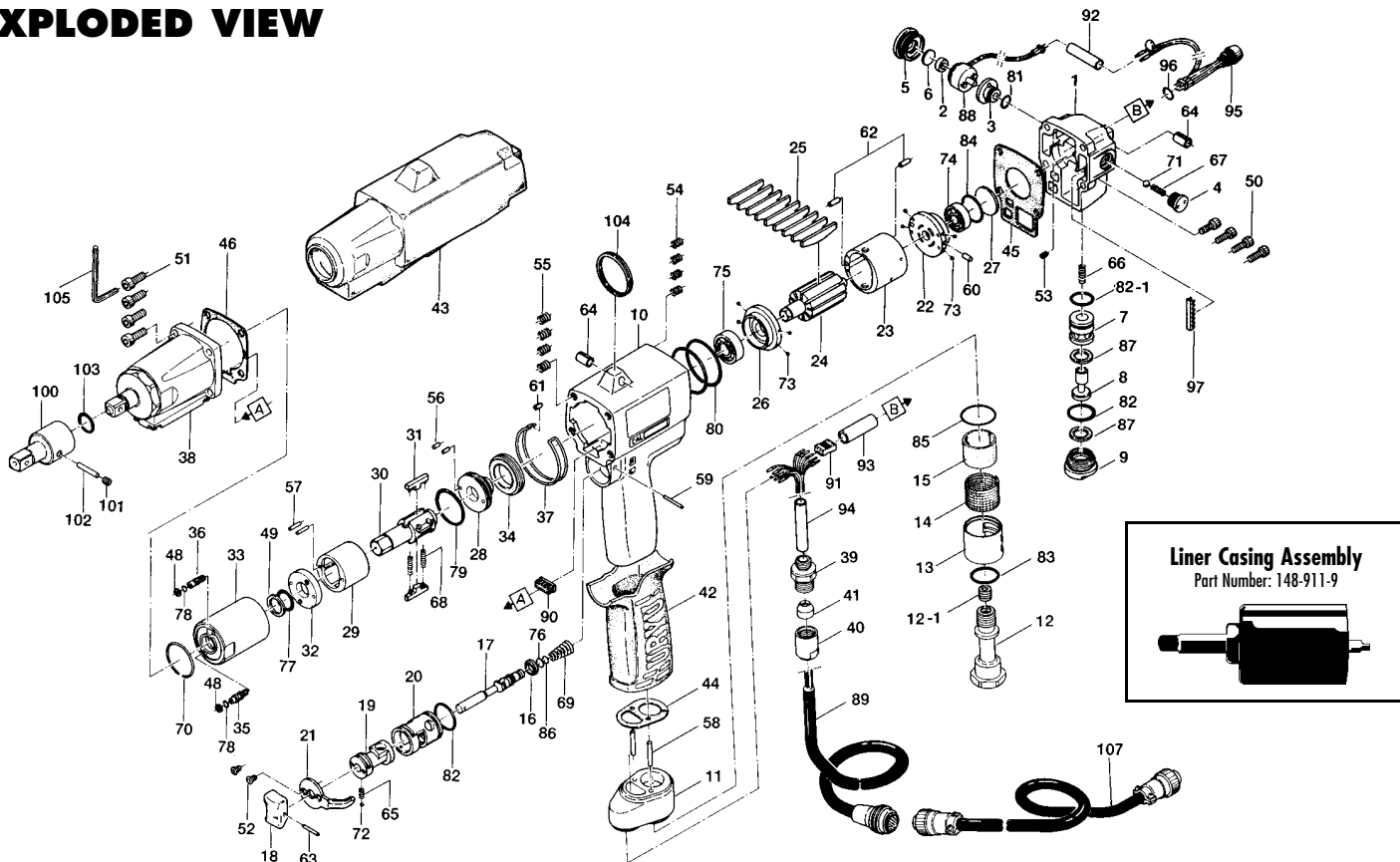

PARTS LIST — FOR REFERENCE ONLY

Index Number	Part Number	Description	Qty.	Index Number	Part Number	Description	Qty.	Index Number	Part Number	Description	Qty.
1	149-012-2	Head Cover	1	36	178-742-0	Oil Plug	1	73	981-045-0	Ball (1.5mm)	2
2	193-120-6	Valve Packing Spacer	1	37	149-754-2	Clip Ring	1	74	982-401-0	Ball Bearing (EE2)	1
3	193-147-6	Stop Valve Bushing	1	38	850-471-1	Sensor Casing Assembly	1	75	982-402-0	Ball Bearing (EE3)	1
4	193-148-6	Stop Valve Cover	1	39	149-079-5	Connector	1	76	990-002-0	O-Ring (P4)	1
5	193-149-6	Stop Valve Plug	1	40	149-018-5	Cap	1	77	990-152-0	O-Ring (P12)	1
6	193-872-6	Valve Packing	1	41	149-562-6	Stopper	1	78	990-320-0	O-Ring (ARP-568-003)	2
7	149-253-5	Shut-Off Valve Bushing	1	42	173-842-0	Handle Cover	1	79	990-329-0	O-Ring (JW1530-19)	1
8	149-254-5	Shut-Off Valve	1	43	149-840-2	Handle Protector	1	80	990-337-0	O-Ring (JW1530-27)	2
9	149-927-5	Shut-Off Valve Cover	1	44	149-850-5	Casing Connector Packing	1	81	990-905-0	O-Ring (SNS-7)	1
10	149-025-2	Casing	1	45	149-853-2	Head Cover Packing	1	82	990-914-0	O-Ring (SNS-16)	2
11	149-035-5	Casing Connector	1	46	149-867-2	Front Casing Packing	1	82-1	990-910-0	O-Ring (SNS-12.5)	1
12	148-091-9	Air Inlet Bushing	1	48	944-002-0	Supporting Ring (2.6 x 4.5 x 1)	2	83	990-916-0	O-Ring (SNS-18)	1
12-1	148-093-7	Air Inlet Bushing Screw	1	49	944-214-0	Supporting Ring (12 x 15.9 x 1.5)	1	84	990-918-0	O-Ring (SNS-20)	1
13	173-780-5	Exhaust Stack	1	50	945-014-0	Allen Head Bolt (M4 x 14)	1	85	990-921-0	O-Ring (SNS-22.4)	1
14	173-042-0	Silencer	1	51	945-117-0	Allen Head Bolt (M5 x 16)	4	86	990-972-0	O-Ring (SNS-4) (NOK)	1
15	173-835-0	Filter	1	52	948-423-0	Allen Flush Head Screw (M3 x 6)	2	87	996-418-0	Packing (15 x 9 x 1)	1
16	173-100-0	Valve	1	53	954-005-0	Allen Head Dog Point Screw (M3 x 5)	1	88	909-915-0	Solenoid Valve Assembly	1
17	173-104-0	Valve Rod	1	54	965-006-0	Heli-Sert (M4 x 1.5D)	4	89	909-926-0	Joint Cable Assembly (WHITE)	1
18	149-107-2	Valve Lever	1	55	965-011-0	Heli-Sert (M5 x 1.5D)	4	90	909-918-0	Double-Row Socket (DF11-12DC-2C)	1
19	151-210-4	Reverse Valve	1	56	970-130-0	Pin (H) (2.45 x 4.5)	2	91	909-733-0	Connector (RF-06)	1
20	151-211-4	Reverse Valve Bushing	1	57	970-135-0	Pin (H) (2.45 x 11)	2	92	909-707-0	Shrink Tube (6 x 30)	1
21	173-212-0	Reverse Lever	1	58	970-208-0	Pin (H) (3 x 10)	2	93	909-708-0	Shrink Tube (8 x 30)	1
22	149-285-2	Rear Plate	1	59	971-125-0	Pin (2 x 25)	1	94	909-738-0	Shrink Tube (6 x 40)	1
23	148-286-9	Cylinder	1	60	973-005-0	Roll Pin (2 x 5)	1	95	909-920-0	LED Lamp Assembly	1
24	148-287-9	Rotor	1	61	973-007-0	Roll Pin (2 x 7)	1	96	990-907-0	O-Ring (SNS-9)	1
25	148-288-0	Blade (PC)	9	62	973-008-0	Roll Pin (2 x 8)	2	97	909-486-0	Free Bushing (KG-024)	1
26	149-289-2	Front Plate	1	63	973-014-0	Roll Pin (2 x 14)	1				
27	193-291-6	Rear Plate Spacer	1	64	973-340-0	Roll Pin (6 x 10)	2				
28	196-901-4	Rear Liner Plate	1	65	976-006-0	Spring (3 x 5 x 0.4)	1				
29	177-902-5	Liner	1	66	976-396-0	Spring (4.6 x 15 x 0.55)	1				
30	149-319-2	Anvil	1	67	976-240-0	Spring (4.3 x 14 x 0.4)	1				
31	177-440-5	Driving Blade	2	68	976-791-0	Spring (3.3 x 21 x 0.4) WPC	2				
32	178-904-8	Front Liner Plate	1	69	977-160-0	Cone Spring (7.4 x 14 x 20)	1				
33	177-905-6	Liner Casing	1	70	978-282-0	Snap Spring (28 x 1)	1				
34	190-906-6	Liner Casing Setter	1	71	981-024-0	Polyurethane Ball (5mm)	1				
35	174-907-8	Relief Valve Spindle	1	72	981-002-0	Ball (1/8)	1				



ACCESSORIES

100	904-090-0	Extension Bar (3/8 x 45MC)	1
101	953-104-0	Allen Head Flat Point Screw (M4 x 4)	1
102	971-214-0	Pin (3 x 14)	1
103	990-011-0	O-Ring (P12)	1
104	004-790-2	Suspension Ring	1
105	939-105-0	Allen Wrench (4mm)	1
107	909-921-0	Sensor Cable Assembly (3F5)	1

FOOTNOTES

Note: Liner Casing Assembly = 148-911-9

AIMCO also offers a complete line of standard & special adapters, bits, sockets and extensions.



AIMCO

When ordering spare parts, please specify tool type, part number and description.
 10000 SE PINE, PORTLAND, OR 97216
 503-254-6600 FAX 503-255-2615